

# Convincing high pressure seals for pipeline pumps

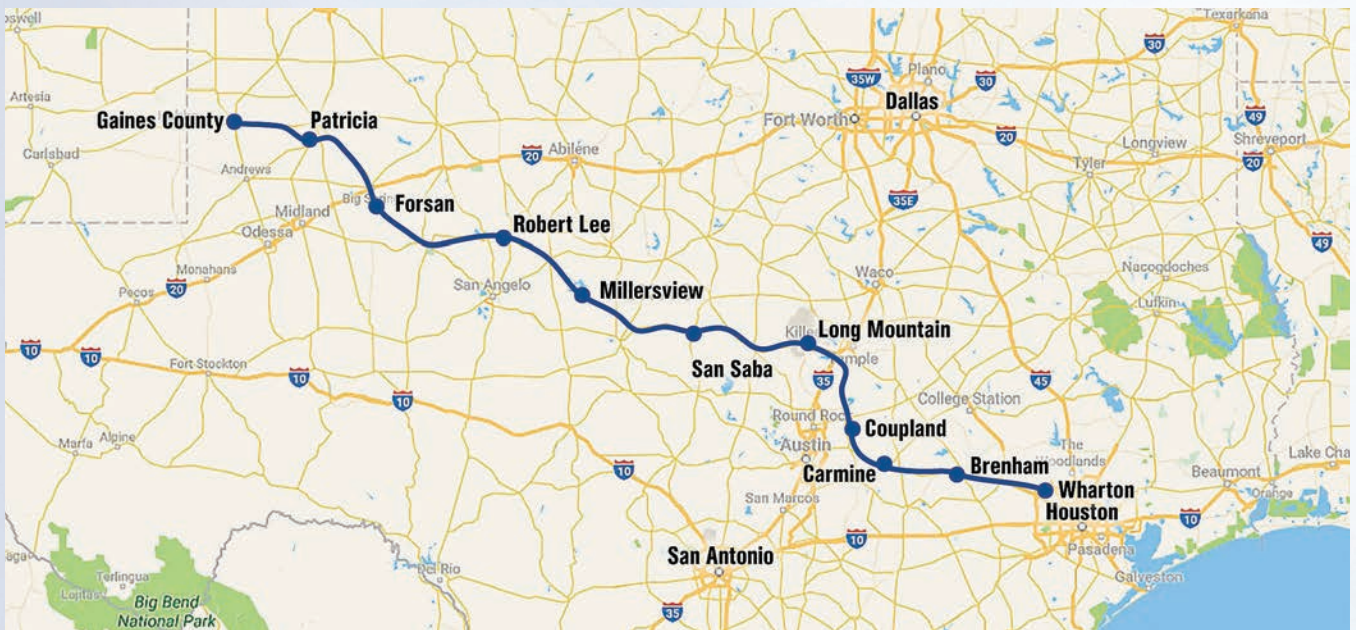

Route of the "Seminole Redline" and locations of its eleven pump stations

**Enterprise Products Partner LP is a US-pipeline operator with headquarters in Houston, Texas, USA. In addition to a large natural and liquid gas network, the company operates oil pipelines with a length of approximately 10,000 km (6,200 mi). The "Seminole Redline" pipeline extends 800 km (500 mi) from the city of Seminole near the New Mexico border via eleven pump stations and ends in north Houston.**

The pump stations are equipped with multistage, axially split multi-fluid pipeline pumps from Bingham and United. These were originally sealed with single and dual competitor seals. The performance of these seals with an MTBR (Mean Time Between Repair) often of only one month resulted in high costs and expenditures for the end user. Among others, the reasons for the failures were the changing properties of the multiple light hydrocarbons and the occurring pressure peaks. Especially problematic: the strongly varying steam pressure of the medium which caused the seal to run dry and fail.

In 2015, the pipeline operator initiated measures to improve the situation and consequently approached EagleBurgmann with two requirements: For one, all pumps installed in the unmanned stations have to be sealed with single seals to prevent maintenance costs for seal supply systems. For another, the unsatisfactory MTBR intervals have to be significantly extended in order to sustainably increase the availability of the pump stations.

**The solution: single seal SHVI with containment seal**

An EagleBurgmann technology team concentrated on designing a reliable and economic seal. The customer was then presented with a solution that was based on the proven single high pressure seal SHVI with an containment seal type CGSH.

Operating conditions	
Suction pressure: $p = 18.2 \dots 44.8$ bar (265 ... 650 PSI)	
Outlet pressure: $p = \max. 75.8$ bar (1,100 PSI)	
Vapor pressure: $0.34 \dots 36.0$ bar (5 ... 523 PSI)	
Temperature: $t = +26.6 \text{ }^\circ\text{C} \dots +29.4 \text{ }^\circ\text{C}$ (+80 °F ... +85 °F)	
Rotational speed: $n = 3,240 \dots 5,400 \text{ min}^{-1}$	
Medium: Ethane/propane mix, natural gas (Y grade), propane, Iso- and n-Butane	

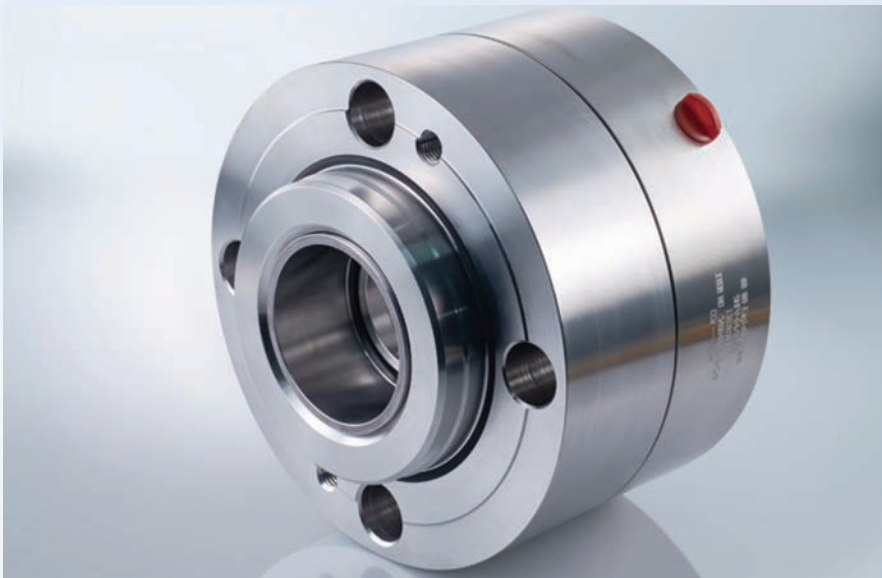

Effective, robust and flexible: seals of the SH range from EagleBurgmann have proved their worth successfully in hundreds of pipeline applications.

The geometries of the seal face and stationary seat of the SHVI product side were optimized with FEM calculations and conditioned for reliable application under all operating conditions and media compositions. The seal faces are designed so that the liquid portion of the medium is vaporized and only gaseous leakage from the product side reaches the CGSH containment seal.

Upon gas entry, the uni-directional U-grooves of the CGSH seal, incorporated in the stationary seat of the seal ensure separation of the seal faces and contact-free and wear-free operation.

The sealing solution was successfully tested at a special rig of the R&D facilities of EagleBurgmann. Despite the critical changing properties of the medium (viscosity, solids and gas content) the shafts of the axially split multi-stage pumps of the customer are securely sealed in all operating conditions.

### Successful retrofit

EagleBurgmann successfully installed several SHVI-CGSH seals in the field. A common seal would typically run for less than 500 hours, meaning roughly one month. The first EagleBurgmann seals to be installed have run over one year without any issues. Thus, the pipeline operator retrofitted all eleven pump stations to the new seals. All in all, eighty seals have been supplied.

The savings in maintenance and repair costs as well as the increase of availability and cost-effectiveness of the pumps and pump station are considerably. The customer is accordingly satisfied.

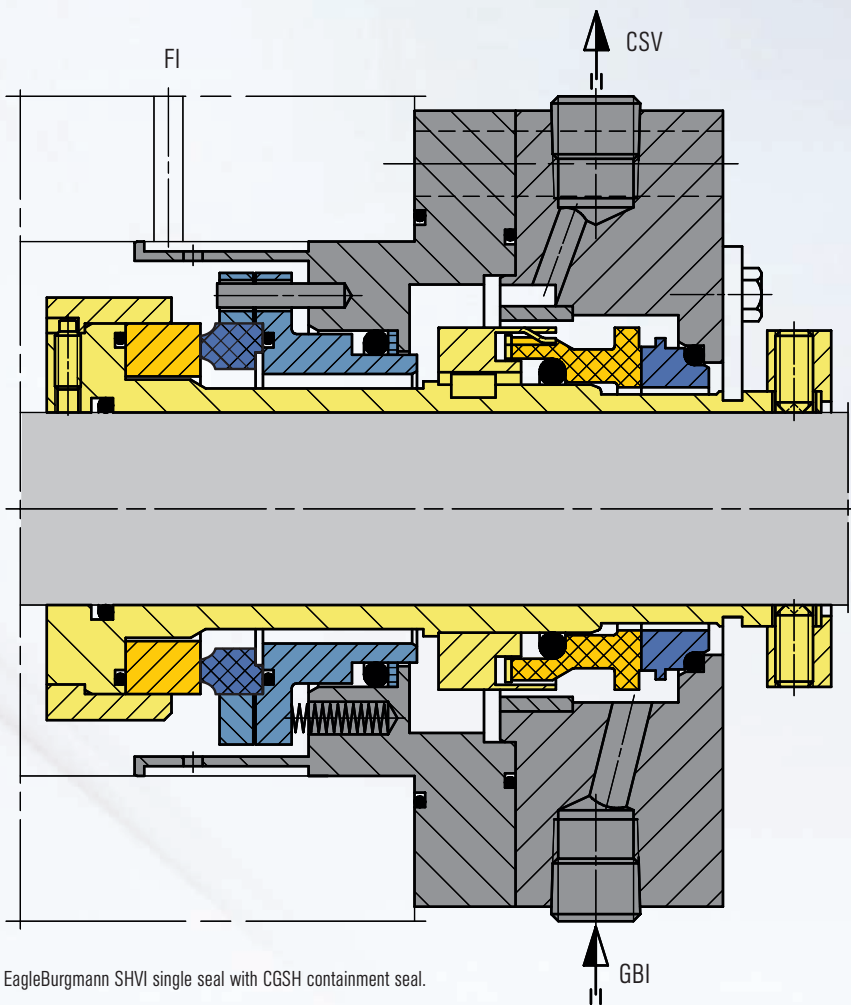

EagleBurgmann SHVI single seal with CGSH containment seal.

- Yellow areas: rotating parts of the seal
- Blue areas: stationary parts of the seal
- Gray areas: pump shaft and housing parts